



## en Translation of the original user manual

### Key to pictograms



ATTENTION



Important information



Read operating instructions/  
safety instructions.



Technical data



Weight



How to use



Do not touch the cutting edge of the blade



Ensure the device is standing securely



Remove paper clips and staples!



Maintenance instructions/troubleshooting



Protect against moisture



Maximum material thickness of the material  
to be cut



Carefully read through the operating instructions and safety instructions before putting the product into operation.



You must follow the instructions! Keep the operating instructions in a safe place ready for later use.

Subject to technical modifications.

### Intended use

The rotary trimmer is intended for cutting of paper and paper-like materials.

Wear and damage due to improper use or unauthorised modifications and repairs are not covered by the warranty or the guarantee.

The rotary trimmer is designed for private use and for use in normal office environment.

The cutting power is specified in chapter <sup>2</sup> Technical data. The given material thickness must not be exceeded under any circumstances. The possible consequences could be injury and damage to the device. Only original Dahle spare parts may be used.

### Safety instructions

You must observe the following instructions:

- The device is not intended for use by persons (including children), who have reduced physical, sensory or mental capabilities or who lack experience and knowledge, unless they are working under supervision or receive detailed instruction about how to use the device from a person who is responsible for safety.
- Never use the head of the blade outside the device.

### How to use

Cutting of paper and paper-like materials.

Chapter <sup>3</sup> contains the instructions in diagram form. Prerequisite:

- The device stands securely.
- Paper clips and staples are removed.
- The head of the blade is on one of the end stops.

*The compression is deactivated.*

Action steps:

1. Insert the material to be cut below the pressure rail and align.
2. Press on the pressure rail  
*The material to be cut is secured against misalignment.*
3. Move the head of the blade along the guide rail. Cutting can be done in both directions.
4. Move the head of the blade in one of the end stops.
5. Remove cut material.

### Maintenance and service

Regularly remove impurities like dust and material residues from the moving parts.

### Replace head of the blade

The rotary trimmer blade is designed in such a way that it sharpens itself when being used. But the blade can still become blunt depending on use. In this case, the head of the blade needs to be replaced. Order and use only Dahle spare parts. Chapter <sup>4</sup> contains graphical representations of the instructions.

2

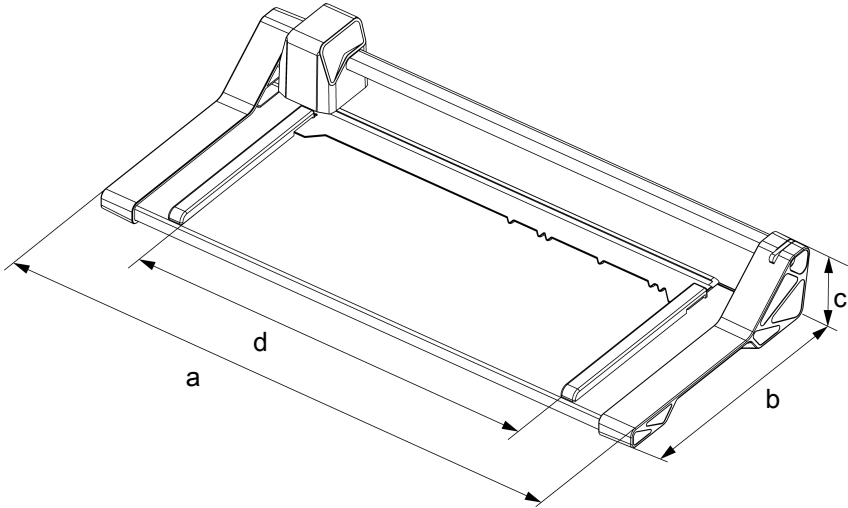

	a [mm]	b [mm]	c [mm]	d [mm]	[mm]	[kg]
507	449	208	73	320	0,8	1
508	589	208	73	460	0,6	1,3

3

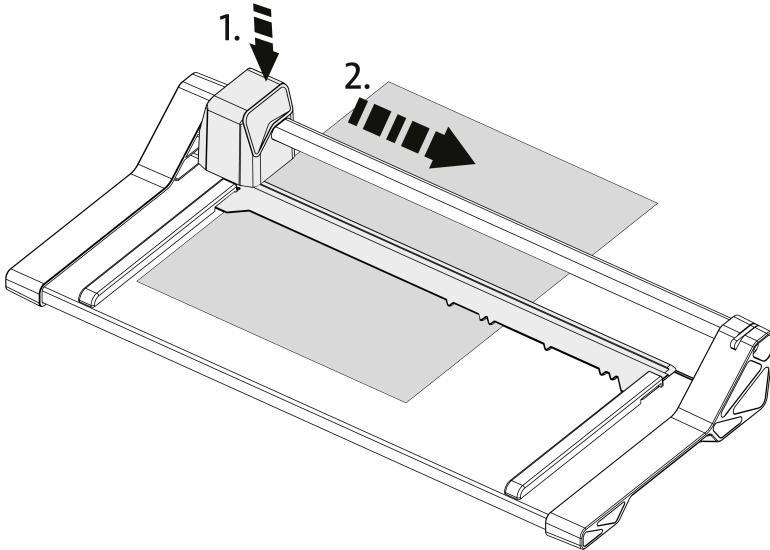
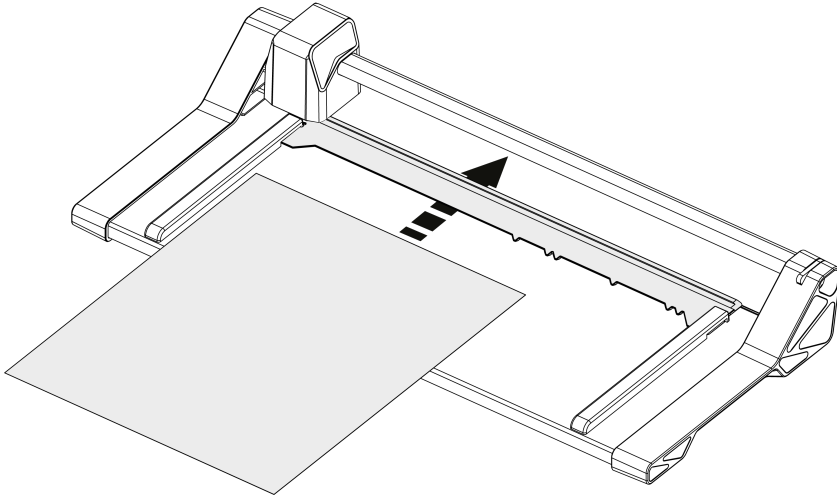

3

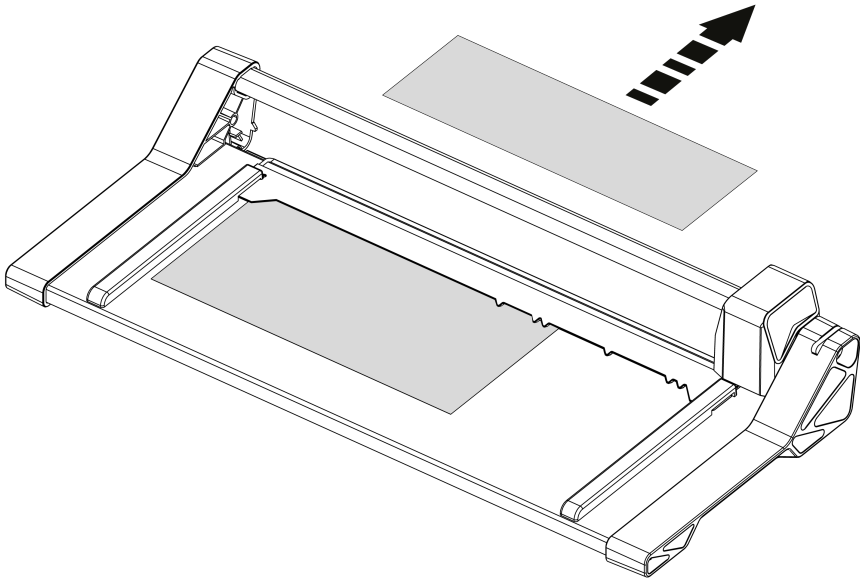

4

