

Foster New! Height Adjustable All-A-Board Lifter®

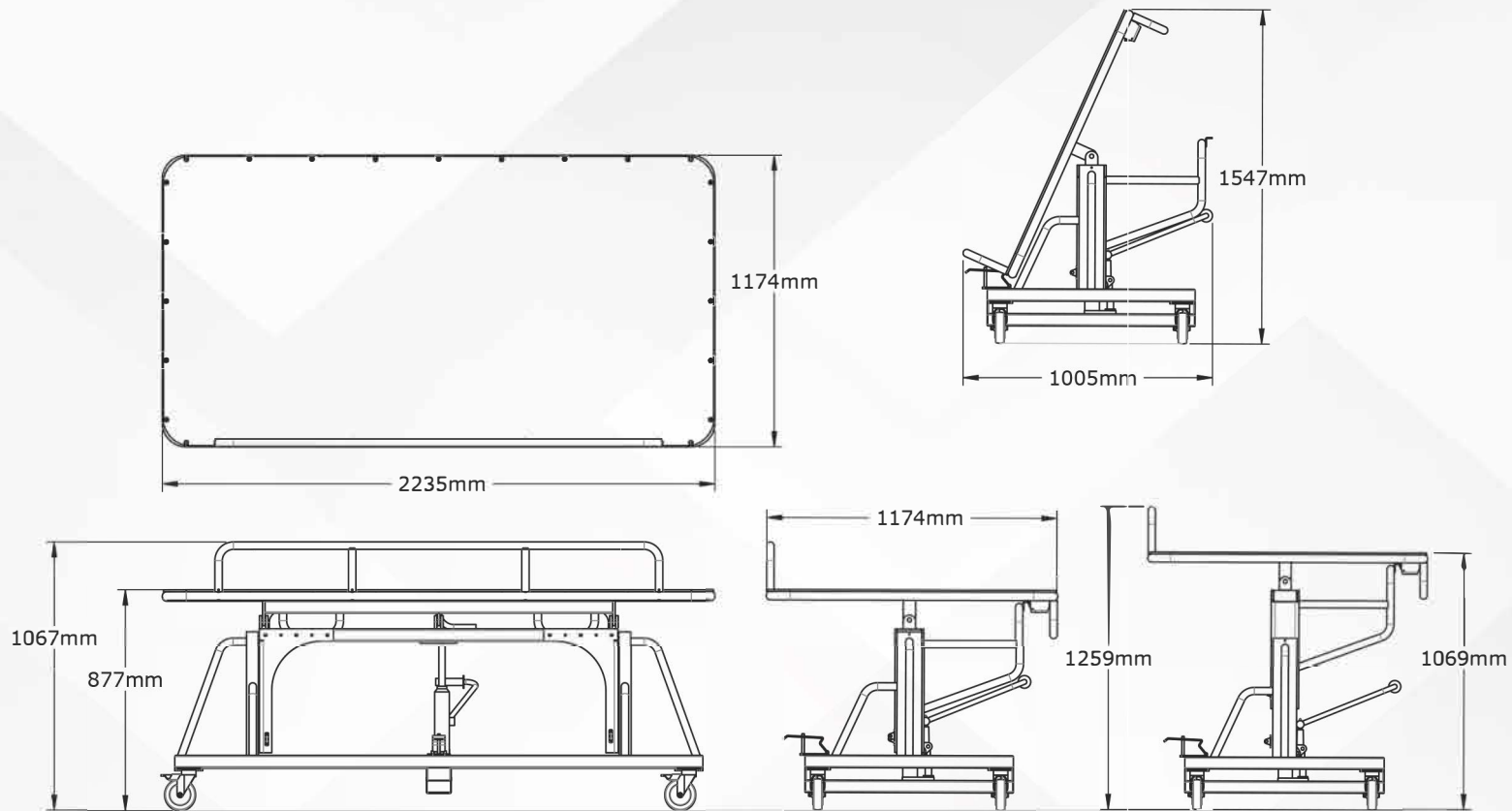

2-year warranty on hydraulics. | 5-year warranty on the frame.

Model #61612 Features and Benefits

- Maximum Board Size 8' x 4'
- Maximum weight capacity 500 lbs.
- Min/Max Deck height 34" - 42" H
- Max. tilting angle 66°(at 32" H)
- 3-ft. wide tilt in the vertical position guides the user through narrow aisles, doorways, and around tight corners
- Functions as a workbench or table in a flat position
- Durable -deck surface fastened to Lifter frame with counter-sunk (flat head cap screw) hardware prevents scratching and is impact resistant
- Four heavy-duty 5" diameter swivel locking casters for smooth maneuvering
- Welded steel frame ensures long-lasting use

Binding101.com | 866-537-2244 | Camarillo, CA 93012

NEW! Height Adjustable All-A-Board Lifter®



ONE OPERATOR can safely handle any job.
Effortlessly load and move heavy rigid substrates through your facility.

"I don't know how Color Reflections could manage without this Lifter!"



"We have machines of many heights in a bustling shop. Thanks to this new Lifter, we can stage several jobs simultaneously on mobile work benches. We are always on a deadline. Foster's Height Adjustable All-A-Board Lifter® moves heavy, rigid substrates along so quickly that we can meet our deadlines. To produce the best graphics, Color Reflections has three vital needs: Reduce injury, expedite production, and make things easier for our employees. **THIS LIFTER DOES ALL THREE.** We have several, and our staff is thrilled."

Eric Berger, Owner
Color Reflections
A leading provider of digital color printing and graphics



Reduce injury when transporting materials thanks to the Lifter's ergonomic design.

Jobs remain in mint condition thanks to the hydraulic foot pump that adjusts in height from 34" to 42" to fit most printers and finishing equipment.

Foster – since 1948, evolving to meet the needs of your printing and graphics company.



NEW! Height Adjustable All-A-Board Lifter®

Reduce injury, expedite production, and make things easier for your team. Ergonomics is an investment that benefits your people and your bottom line.



ONE OPERATOR can safely handle any job. Effortlessly load and move heavy rigid substrates through your facility.



In a flat position, the Lifter functions as a mobile workbench that quickly moves from station to station. This frees up valuable floor space while operators can work on multiple jobs requiring different steps for finishing.



Operators can quickly and safely feed boards onto printers, cutters, and laminators without bending or lifting.



One operator can move 500 lbs. of rigid substrates from warehouse to printing to finishing with minimal effort. Shops have so much equipment in a limited amount of floor space. These tables revert to a 3-ft-wide space.



Deck rails keep 8" stacks of rigid substrates from shifting and moving during transport and loading.

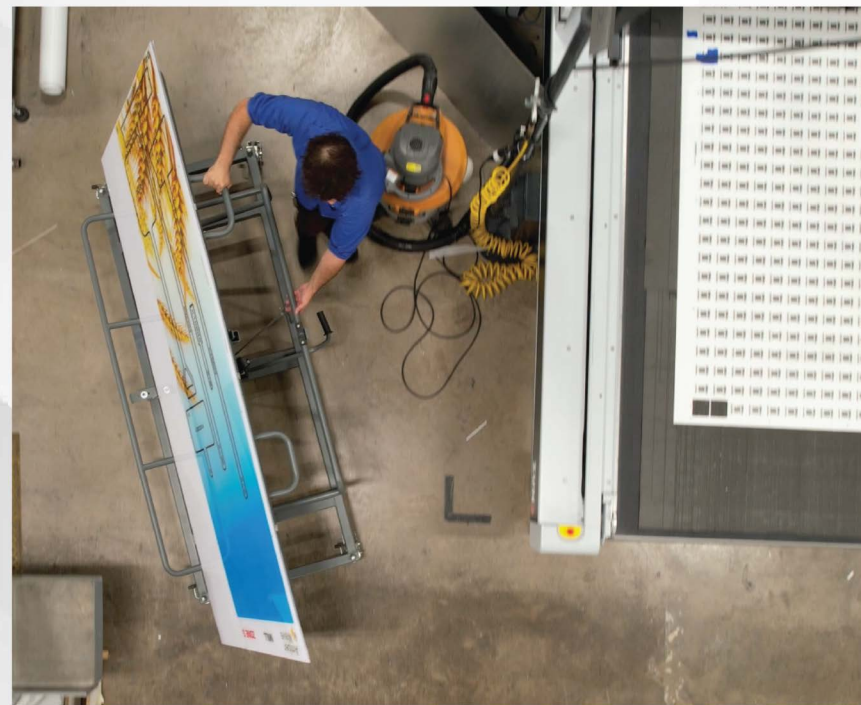

Save time with Foster's new Lifter that easily slides through doorways—no more carrying jobs to a workbench or printer.



The tilt down and locking feature lets the operator safely move heavy rolls from horizontal to vertical position.



Latch releases and locks on top of work surface.

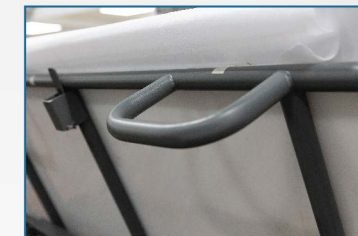

Handlebar under the table for easy maneuvering of materials and rotating from vertical to a flat position.

Contact Binding101 today at 866-537-2244 or info@buy101.com